

EMC® POWERJET® AUTOMATIC PARTS WASHERS

OWNER'S MANUAL FOR INSTALLATION AND OPERATION OF

**MODELS: 50E, 80E, DS80E,
100E, T100E, DS100E, PT100E,
100G, T100G,
150G, T150G, DS150G, PT150G,
200G, T200G, DS200G, PT200G,
150E, T150E, DS150E, PT150E,
200E, T200E, DS200E, PT200E.**

***READ THIS MANUAL BEFORE SET-UP, CONNECTION and USE of PARTS WASHER,
and SAVE FOR FUTURE REFERENCE !***

Enter your unit's data here for future reference: **MODEL NUMBER** _____
SERIAL NUMBER _____
PURCHASE DATE _____

EQUIPMENT MANUFACTURING CORPORATION
Santa Fe Springs, CA. 90670

WebSite: www.equipmentmanufacturing.com

EMC® POWERJET® **MANUAL**

ATTENTION ! OWNER AND OPERATOR ! IMPORTANT INSTRUCTIONS !
BEFORE CONNECTION AND USE OF YOUR POWERJET® PARTS WASHER,
PLEASE READ THIS ENTIRE MANUAL AND SAVE IT FOR FUTURE REFERENCE !

TABLE OF CONTENTS

| Subject | Page |
|---|-----------|
| MANUAL COVER and TITLE | 1 |
| TABLE OF CONTENTS | 2 |
| I. INSTALLATION INSTRUCTIONS | 2 |
| A. LOCATION & SET-UP | 3 |
| CABINET DIMENSIONS | 3 |
| II. UTILITIES INSTALLATIONS | 4 |
| 1. ELECTRIC CONNECTIONS | 4 |
| A. THREE-PHASE HEATER HOOK-UP | 4 |
| B. THREE PHASE LINE HOOK-UP | 4 |
| 2. GAS CONNECTION | 4 |
| Cabinet Illustration, Vent Stack I.D. & Tank Capacity | 5 |
| III. PREPARATION | 6 |
| A. SOAP & WATER SOLUTION | 6 |
| B. BULLETIN: Rust & Corrosion of Parts Washers | 6 |
| C. WATER LEVEL | 6 |
| IV. OPERATION | 7 |
| A. AUTOMATIC SETTINGS | 7 |
| B. START WASH CYCLE | 7 |
| C. OIL SKIMMER | 7 |
| V. MAINTENANCE | 8 |
| A. DAILY | 8 |
| B. WEEKLY | 8 |
| C. MONTHLY | 8 |
| D. ANUALLY | 8 |
| E. STORAGE | 8 |
| REMOVAL of IMPELLER to Replace Standard PUMP SEAL | 9 |
| INSTALLATION of Standard PUMP SEAL | 10 |
| WIRING DIAGRAMS, | |
| Standard 50E - 80E - 100E series, 220Volt Electric heat | 11 |
| Single-Phase Conversion – Hook-Up Instructions | 12 |
| Standard 150E - 200E series, 220Volt Electric heat | 13 |
| Standard 150G - 200G series, 220Volt GAS heat | 14 |
| POWERJET PARTS LIST | 15 |
| PUMP PARTS LIST | 16 |
| Wayne GAS BURNER PARTS LIST | 17 |
| POWERJET Accessories | 17 |
| Old Atmospheric-Style GAS Burner Parts | 18 |
| SPECIFICATIONS | 19 |
| WARRANTY & LIMITATION of LIABILITY | 20 |

! ATTENTION !

EMC POWERJET *Automatic Parts Washers*, equipped with a **Standard 120GPM pump & 1½HP motor** assembly, are shipped from the factory with **One Extra / Spare PUMP SEAL ! (GRAINGER part no.1R303)**. The **spare PUMP SEAL** is in a small box (1½" x 1½" x 1½"), included in the plastic bag along with this Owner's Manual.

IMPORTANT !

Please **SAVE** both the **PUMP SEAL** and
this **MANUAL** for future use and reference !

I. INSTALLATION INSTRUCTIONS

Remove ALL shipment bands and plastic wrap !

**The POWERJET unit must be removed
from Shipping Pallet!**

**Set-Up POWERJET with ALL 4 Legs and Foot Pads
DIRECTLY ON SOLID LEVEL FLOOR !**

A. LOCATION & SET-UP :

Position your **EMC POWERJET** Automatic Parts Washer cabinet on level floor. The foot pads at bottom of washer legs are designed only for leveling or bolting the unit to the floor. Use bolt and large washers as shims under foot pads to level the legs. The Foot Pads are Not suitable for and should Not be used for mounting to wheels or casters.

Adjust so the Washer cabinet sits level and square, side to side. This will allow the door to seal properly around the door frame.

The Cabinet VENT is located on the top right rear of washer. This vent is designed to accommodate expanding air and water vapor, when the washer pump is first turned on. Some additional vent stack may (or may not) be necessary, according to your preference and location of washer. Since some water vapor (and soap residue) may be emitted from this vent from time to time, and will deposit back down on the washer, or other equipment in the area, walls, personnel, etc., ...you may want to run some additional venting to the outdoors (*straight up thru the roof works best*), OR, if you prefer, up and over, then down to a container or bucket where the water can drip into.

! IMPORTANT !

Upper vent sections must be lapped so condensation funnels inward, into the lower vent sections, just the opposite of a Gas Burner exhaust stack.

Otherwise, the water runs down the outside of the stack and under the washer's insulation jacket, eventually dripping from bottom of the washer.

This is often mis-diagnosed as a leak.

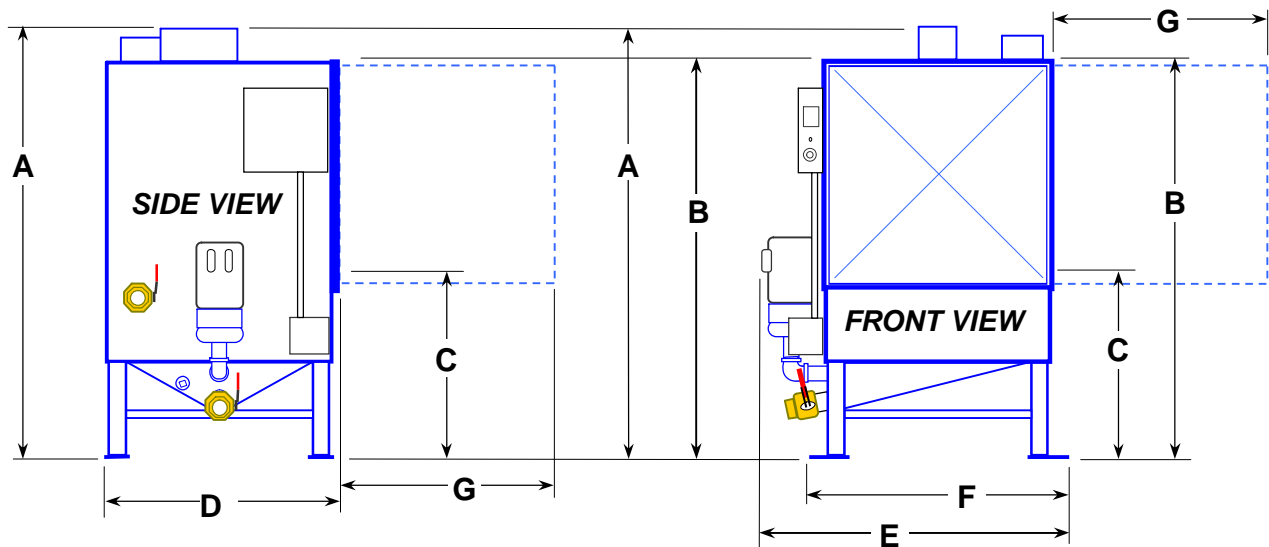
CABINET OVERALL DIMENSIONS

| Model No. | A Total Clearance Height | B Basic Frame Height | C Floor to Top of Turntable Height | D Depth, Front to Rear | E Total Width, Side to Side | F Foot Pad Width, Side to Side | G Plus, Open Door Swing Clearance |
|-------------------|-----------------------------------|-------------------------------|---|---------------------------------|-----------------------------------|---|--|
| E | | | | | | | |
| L 50E | 72" ± | 66" ± | 34" ± | 33" ± | 44" ± | 35½" ± | add 30" ± |
| E 80E | 80" ± | 74" ± | 34" ± | 33" ± | 44" ± | 35½" ± | add 30" ± |
| C DS80E | 116" ± | 110" ± | 34" ± | 33" ± | 44" ± | 35½" ± | add 30" ± |
| T 100E | 80" ± | 74" ± | 34" ± | 39" ± | 50" ± | 41½" ± | add 36" ± |
| R T100E | 92" ± | 86" ± | 34" ± | 39" ± | 50" ± | 41½" ± | add 36" ± |
| I DS100E | 116" ± | 110" ± | 34" ± | 39" ± | 50" ± | 41½" ± | add 36" ± |
| C * PT100E | 112" ± | 89" ± | 33" ± | 49" ± | 55" ± | 41½" ± | (112" ± Tall) |
| W 150E | 80" ± | 74" ± | 34" ± | 51" ± | 63½" ± | 53½" ± | add 48" ± |
| A T150E | 92" ± | 86" ± | 34" ± | 51" ± | 63½" ± | 53½" ± | add 48" ± |
| S DS150E | 116" ± | 110" ± | 34" ± | 51" ± | 63½" ± | 53½" ± | add 48" ± |
| H * PT150E | 112" ± | 89" ± | 33" ± | 61" ± | 67" ± | 53½" ± | (112" ± Tall) |
| E 200E | 80" ± | 74" ± | 34" ± | 63" ± | 75½" ± | 65½" ± | add 60" ± |
| R T200E | 92" ± | 86" ± | 34" ± | 63" ± | 75½" ± | 65½" ± | add 60" ± |
| S DS200E | 116" ± | 110" ± | 34" ± | 63" ± | 75½" ± | 65½" ± | add 60" ± |
| S * PT200E | 112" ± | 89" ± | 33" ± | 73" ± | 79" ± | 65½" ± | (112" ± Tall) |
| G 100G | 80" ± | 74" ± | 34" ± | 39" ± | 51" ± | 41½" ± | add 36" ± |
| A T100G | 92" ± | 86" ± | 34" ± | 39" ± | 51" ± | 41½" ± | add 36" ± |
| S DS100G | 116" ± | 110" ± | 34" ± | 39" ± | 51" ± | 41½" ± | add 36" ± |
| S * PT100G | 112" ± | 89" ± | 33" ± | 49" ± | 56" ± | 41½" ± | (112" ± Tall) |
| W 150G | 80" ± | 74" ± | 34" ± | 51" ± | 63½" ± | 53½" ± | add 48" ± |
| A T150G | 92" ± | 86" ± | 34" ± | 51" ± | 63½" ± | 53½" ± | add 48" ± |
| S DS150G | 116" ± | 110" ± | 34" ± | 51" ± | 63½" ± | 53½" ± | add 48" ± |
| H * PT150G | 112" ± | 89" ± | 33" ± | 61" ± | 68" ± | 53½" ± | (112" ± Tall) |
| E 200G | 80" ± | 74" ± | 34" ± | 63" ± | 75½" ± | 65½" ± | add 60" ± |
| R T200G | 92" ± | 86" ± | 34" ± | 63" ± | 75½" ± | 65½" ± | add 60" ± |
| S DS200G | 116" ± | 110" ± | 34" ± | 63" ± | 75½" ± | 65½" ± | add 60" ± |
| S * PT200G | 112" ± | 89" ± | 33" ± | 73" ± | 80" ± | 65½" ± | (112" ± Tall) |

"PT" or "Pass-Thru" model is not depicted in above drawing.

II. UTILITIES INSTALLATION

Find your Washer's ID Plate located on the upper left side of the washer cabinet, above the main Control Box.



Check your power source, for a properly fused power supply as to Voltage, Phase, Cycles and Amps, as called for on your Washer ID Plate !

Remember:

From the EMC Factory, ALL 220Volt & 440Volt units are Wired for **3 PHASE** operation ONLY !

- But, Only the 220Volt unit can easily be Converted to Single-Phase, at your hook-up and installation.

(Requires a Single-Phase pump Motor)

(see Single-Phase Conversion & Wire Diagram on page 12)

1. ELECTRICAL CONNECTION:

To be performed by Qualified Personnel !

**DISCONNECT and LOCK-OUT POWER
PRIOR TO PROCEEDING !**

NOTE: Make sure all washer control knobs are in the "OFF" position before connecting washer to utilities.

A. THREE PHASE LINE HOOK-UP:

1. Locate the Heater Contactor inside the Main Control Box at the lower left. (see Wiring Diagrams page 11, 13, 14)

2. LINE HOOK-UP is to the Three Terminals on the LEFT side of the Heater Contactor.

→ ATTENTION !

Here you will find 3 short Test Lead wires or "Pig Tails" used at the Factory for Testing purposes.

These "Pig Tails" also mark the Three Terminals to connect your power source to.

You **Must Remove** the "Pig Tails" before connecting your power source.

Do NOT connect your power source to these "Pig Tails".
Do NOT use "Wire Nuts".

3. Connect to properly fused **220V**olt, 60 Hz, **3-Phase** (3Ø) power source **as called for on the Washer ID plate.**

OR

Connect to a properly fused **440V**olt, 60 Hz, **3-Phase** (3Ø) power source **as called for on the Washer ID plate.**

IMPORTANT ! Check that Rotation direction of Pump Motor is Clock-Wise, as viewed from top of Motor! (440Volt units and ALL 3 PHASE pump MOTORS)

4. GROUND Hookup is to the chassis of the washer.

! IMPORTANT !

The chassis of this washer MUST be Properly Grounded !

B. THREE PHASE HEATER HOOKUP:

These Washers have 3 or more Immersion Heaters. Each Heater draws approximately 18 amps each. The Heating Element wires entering the bottom of the main Control Box are colored to represent one Heater per pair of wires with the same color.

Remember:

From the EMC Factory, ALL 220Volt & 440Volt units are Wired for **3 PHASE** operation ONLY !

- But, Only the 220Volt unit can easily be Converted to Single-Phase, at your hook-up and installation.

(Requires a Single-Phase pump Motor)

(see Single-Phase Conversion & Wire Diagram on page 12)

To be performed by Qualified Personnel !

**DISCONNECT and LOCK-OUT POWER
PRIOR TO PROCEEDING !**

1. The HEATER CONTACTOR is located inside the Main Control Box at the lower left.
2. All 3 terminals on the right side of the Heater Contactor are used.
3. Two Heater Wires of different color connect to each right side terminal.
4. Two Heater Wires of the same color must **NEVER** go into the same terminal.

2. GAS CONNECTION:

To be performed by Qualified Personnel !

**DISCONNECT and LOCK-OUT POWER
PRIOR TO PROCEEDING !**

NOTE: Make sure all washer control knobs are in the "OFF" position before connecting washer to utilities.

1. Gas Heated unit is designed for NATURAL GAS.
2. A separate Gas Line Shut-Off Valve is recommended and should be located near the washer.
3. Connect a Standard Low Pressure 7"-14" W.C. (½" PSI max.) Natural Gas line, to the ¾" NPT gas inlet at the back of the Burner housing, (located at the lower left side of washer just forward of the pump & motor).
4. VENT the Gas Burner's Heat & Exhaust Stack, located at the left rear corner of the washer, to the OUTDOORS !
5. For Calibration & Troubleshooting, refer to the Burner Manual.
6. To Convert To PROPANE, refer to Burner Manual, or consult with factory for fuel conversion applications.

(Burner Jet size for natural Gas is #358)

(Jet size for Propane is smaller)

EMC® POWERJET® Cabinet Illustration

| Model Numbers | VENT STACK Inside Diameter | Water Solution TANK CAPACITY |
|--|----------------------------|------------------------------|
| 50E | 4 inch | 50 gallon |
| 80E | 4 inch | 80 gallon |
| DS80E | 6 inch | 80 gallon |
| 100E DS100E T100E PT100E | 6 inch | 100 gallon |
| 150E 150G T150E T150G PT150E PT150G | 10 inch | 150 gallon |
| DS150E DS150G | 12 inch | 150 gallon |
| 200E 200G T200E T200G DS200E DS200G PT200E PT200G | 12 inch | 200 gallon |

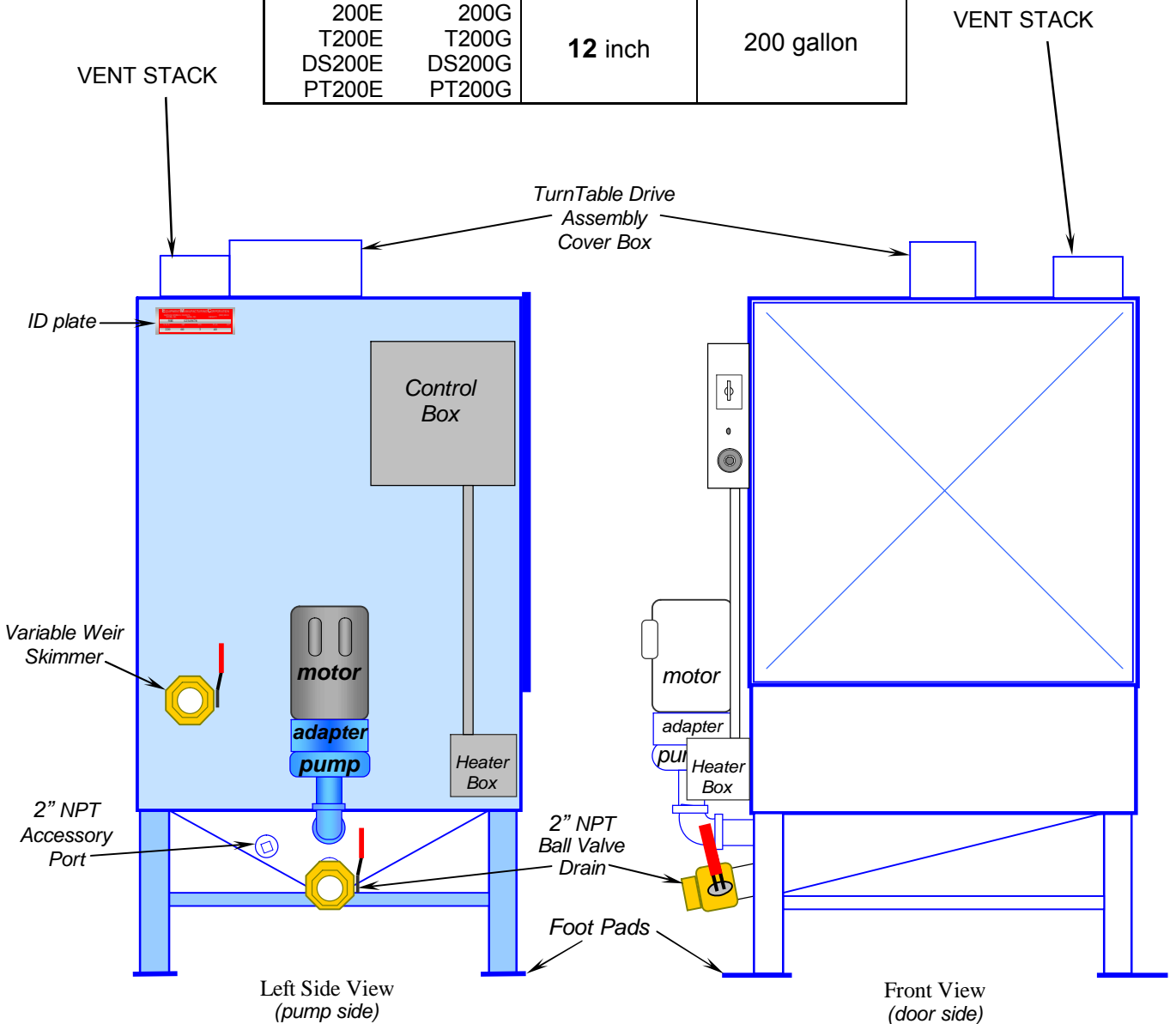

Models: **50** series thru **200** series.

Standard models depicted only.
Drawing not to scale.

III. PREPARATION

WARNING !

**AVOID DAMAGE TO YOUR WASHER !
READ AND FOLLOW THESE INSTRUCTIONS !**

**EMC Parts Washers are Designed for Use
with Non-Flammable, Water-Soluble SOAP,
with Rust Inhibitors !**

DO NOT use Petroleum Solvents !

**DO NOT allow Accumulation of Washed-Off
Flammable Materials !**

A. SOAP & WATER SOLUTION :

1. Check with your local chemical suppliers as to the proper soap to use for your cleaning situation.

Follow your individual soap manufacturer instructions and precautions as to the use and handling of Soap products and Hot water, and the use of protective gear such as: face shields, rubber aprons, gloves, boots, etc., to prevent injury from contact with Soap and HOT parts.

2. DRY SOAP MUST BE PROPERLY MIXED with WATER!

! WARNING !

***Undissolved Soap, clumped up on floor of washer,
can create a chemical reaction, capable of corroding
through the steel floor! . . .***

*(see following section **B. BULLETIN**)*

A. Soaps must be Pre-mixed with warm water,
in a container or bucket, (allow up to 30 min.) . . .

. . . **OR** . . .

B. Soaps can be Pre-mixed in the washer, as follows:

- 1) Fill the Washer with Water, to the proper level
(see section: C. WATER LEVEL)
- 2) Set Thermostat to 160° F, and bring the water up to
Operating Temperature (usually 160° F in most cases)
- 3) Place proper amount of soap in a pan on the Turn Table.
 - Check with your Soap Supplier * for correct
amount of soap to use.
- 4) Run Washer, for up to **30 minutes**, until soap is
properly mixed (*completely dissolved into solution*).

! CAUTION !

Unit is HOT during operation !

Allow to cool before handling washer and contents.

**Use protective gear such as face shields,
rubber aprons, gloves, boots, etc. !**

footnote: **EMC is Not a Soap Supplier. ***

*If you received some Soap with your washer, it was included
by the Distributor / Sales Rep that sold the unit to you*

B. Bulletin:

RUST & CORROSION of PARTS WASHERS with Carbon Steel Components

It is well known that ordinary carbon steel exposed to plain water will oxidize or 'rust'. The vast majority of *Water Based Solution Automatic Parts Washers* are made of Carbon Steel. Although Stainless Steel is available, it's cost often makes it prohibitive

Therefore, carbon steel Parts Washers are designed for use with water and soap with rust inhibitors. The rust inhibitors not only protect the washer cabinet but also the customers steel and iron items being washed in it. Without the proper rust inhibitor, the washer cabinet and the parts you wash in it, will rust!

There are basically 3 reasons why a parts washer will rust

1. Using a soap, which has **no** rust inhibitor in it.
 - Make sure the product being used is designed for this application.
 - If pressed too hard for price, some suppliers will sell a "cheaper" product (i.e. laundry soap).
2. Too little concentration of soap, - which means too little rust inhibitor.
 - Check your water to soap mixing ratio as recommended by the soap manufacturer / supplier.
 - Soap may be carried out on parts being washed.
 - If you only add make up water without additional soap, you have in turn reduced the soap concentration.
3. Often, operators will dump powdered soap into the parts washer with no concern about whether the soap is properly mixed with the water. . . *Despite clear instructions to the contrary in our operator's manual !*
 - The unmixed soap will settle on the washer floor, turning into what may look like " a chunk of concrete" or "a slab of salt". A chemical reaction between the block of solid soap and the floor of the washer can corrode holes in the floor of the washer.
 - Also, since the soap, and its rust inhibitors, are on the floor and not mixed with the water, the interior of the washer may begin to rust.

To wrap up, quite simply, steel will react with what it comes in contact with.

Over the years and thousands of washers later, we have only seen steel rust when exposed to things which ordinarily cause rust, *such as water without rust inhibitors !*

Equipment Manufacturing Corporation
Santa Fe Springs, California

C. WATER LEVEL :

1. **FILL and MAINTAIN WATER LEVEL** above the center of Wash-Area Filter Screen located under TurnTable.
 - a) Open the washer door and fill the tank with water using a hose or buckets.
 - b) Maximum water level is up to the lower spray manifold, or in the range of the 2" ball valve Variable Weir skimmer.
 - c) Washer is equipped with a Low Water Level, Float Switch, Shut-Off System.

HINT:

If Washer fails to operate, check if Water Level is too Low !

WARNING !

**If Water Level drops too Low,
heating elements can be damaged !**

*Do Not rely on the Low Level Switch for maintenance of Water Level !
Water Level should be checked every day the washer is used !*

IV. OPERATION

! CAUTION ! Unit is HOT during operation ! Allow to cool before handling washer and contents

A. AUTOMATIC SETTINGS:

1. SEVEN DAY TIMER,

It is located on the REAR of main Control Box

- a) It Allows Heating System and Thermostat to operate.
 - 1) Pull out red or black 'tripper' pins on dial, to set desired "**ON**" times.
 - 2) Turn dial clockwise until the correct time of day lines up with TIME arrow.
 - 3) **Set Thermostat Dial** on front of main control box, heating will now be automatically controlled.

HINT: If all the Timer pins are pushed in, the Heating System will not start !

4. THERMOSTAT:

It is the lower dial knob and indicator light on FRONT of Control Box.

- a) Allows Heating System to HEAT and Maintains the Water Temperature as indicated on dial.
 - 1) **Set Temperature according to Soap Manufacturers recommendation !**
 - 2) Be sure the Seven-Day Timer is in the **ON** position.
 - 3) The **red light** comes **on** while **heating** and goes **off** when desired **temperature is reached**.

B. START WASH CYCLE:

1. Open washer door and place your parts to be cleaned on the TurnTable.

- a) Use the proper parts baskets or racks as needed to hold or contain, loose or small parts.

2. Wash Cycle TIMER:

- a) Is a **30-Minute** Timer knob and indicator light, located at the upper front of control box.
 - 1) **Close washer door and latch.**
 - 2) Rotate timer switch clockwise to desired time, for your operation and type of soap.
 - a) This will activate the pump and turntable.
 - b) The **red light** indicates wash cycle timer is on.

CAUTION : NEVER open washer door before turning OFF the Wash Cycle Timer. NEVER rely on the door safety switch.

! CAUTION ! Unit is HOT during operation ! Allow to cool before handling washer and contents.

C. VARIABLE-WEIR OIL SKIMMER:

This is the **upper** brass 2" Ball Valve, with a red handle, located on the left side of the washer.

The **lower** brass Ball Valve is the tank Drain.

1. At end of the day, when *POWERJET* is Shut Off, be sure Water Level is in the range of the 2" Ball Valve (Variable Weir Skimmer)
2. Allow enough time for water and oil to separate.
3. Skim Floating Oil, **before operating the pump.**
 - a. Have a container ready for oil to drain into, and place it under brass Ball Valve Weir at side of washer.
 - b. Open ball valve and adjust to the depth of floating oil, so oil, not water, runs out into your container.
4. Remember to CLOSE the VALVE **before starting the POWERJET.**

V. MAINTENANCE

A. DAILY:

WATER LEVEL:

- 1) Water **MUST** be above the center of Filter Screen, or in the range of the 2" ball-valve Variable Weir.
- 2) Maximum level is up to the lower spray manifold.
- 3) Check and top off at the end of **each day**.
- 4) **Do Not** rely on Low Level Float Switch to maintain proper water level.

WARNING !

If water level drops too low, heating elements can be damaged !

B. WEEKLY:

1. **LOW LEVEL SWITCH:** Washer is equipped with a **Low Water Level Shutdown Float Switch**.
 - The Switch is located inside the cabinet, near the front lower left, below water level, mounted to thermostat sleeve.

CAUTION ! This is right next to Heater Elements!
Wait for washer to cool before inspecting!

- A) Check Float Switch Ball for free up and down movement on shaft. (Float Ball is 2" diam. chrome/silver color)
- B) **Float and Shaft must be kept clean** to allow free movement.
 - 1) Remove clip on top of shaft and remove float to clean shaft.
 - 2) **Float Ball** **MUST** be re-installed in the correct **UP** position.
 - Look around the center line of the Float Ball for the "stamped letters" **NO** (Normally Open) - or - **O** (Open).
 - OR, look for "hand-etched" **O**.
 - This marked half of the Ball must be in the **UP** position.

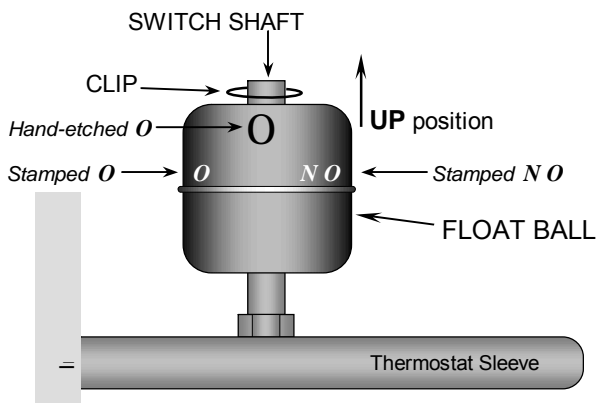

Caution : Inverting this Float Ball position will **Reverse** the On-and-Off Function of the washer.

2. SPRAY MANIFOLD :

- A) Clean jet-spray holes weekly or as needed.
 - 1) Use blast of air or small wire to poke out debris clogging up spray holes.
 - 2) Remove wash out plug located in upper right corner of manifold.
 - 3) Close door and operate wash cycle timer for 30 seconds.
 - 4) Replace wash out plug.

Note: The manifold jets/spray Holes are 7/64" diameter, (just under 1/8")

C. MONTHLY or AS NEEDED:

1. WASH AREA FILTER SCREEN :

- A) Located under the Turntable, is a flexible sheet of perforated steel, that simply slides in and out along side support rails.
- B) Usually needs to be cleaned only when changing solution.

2. DRAINING and CHANGING SOLUTION :

- A) Depending on your particular cleaning situation and volume of activity, the Soap & Water solution in your washer, will need to be changed from time to time. In some cases this can be every week, or twice a month, or once a month, or even less often, but in any situation the solution should not be used beyond 90 days.
- B) Wastewater should be disposed of by approved methods only ! *Check with your local authorities !*
 - 1) Have suitable container and/or plumbing hooked up to 2" Drain Valve located at bottom left side of washer.
 - 2) Open 2" Drain Valve and allow wash solution to drain out.
 - 3) Pull out and wash off Wash Area Filter Screen.
 - 4) Hose out any debris left after draining.
 - 5) Close 2" Drain Valve and fill with fresh water and soap solution. (see previous soap mixing instructions)

D. ANNUALLY :

1. Pump motors with grease fittings require one shot of grease twice per year. Except for door hinges and catch, no other lubrication is required.
2. Pump Seals wear out and eventually will need to be replaced, approximately 2 to 3 years on average.

A spare Pump Seal is included with every new **POWERJET** equipped with a *Standard Pump & 1½HP Motor Assembly*. Pump Seals are also available at a **GRAINGER SUPPLY** in your area, . . . **GRAINGER part no. 1R303**.
See following pages on Pump Seal Replacement !

E. STORAGE:

If your Parts Washer is not going to be used for an extended period of time (3 months, 6 months, a year or more !), it should be properly prepared for storage, to avoid damage to the unit.

Even though the soap and water solution in the washer has Rust Inhibitor in it, during a period of non-use the soap and inhibitors can precipitate out or settle, and your cabinet will rust and corrode!

Also, any water left in the tank will induce moisture to cling to the walls inside the cabinet, where rust and corrosion will occur.

1. You will need to drain the unit of all water and soap solution.
 - WasteWater should be disposed of by an approved means only. *Check with your local authorities !*
1. Remove all debris inside of cabinet and clumps of soap that may have settled to the wash tank floor.
2. Hose out the cabinet walls and tank to rinse off any corrosive substances that may be remaining.
3. Allow the inside of cabinet to DRY thoroughly (spray wash area, turntable, and wash tank)
4. Prop open the door of washer, while it is in storage and not being used, so air can circulate into cabinet to keep it dry !

The following info does **NOT** apply to units equipped with a Heavy Duty SEALLESS Pump & Motor (5HP or 2HP) assembly !

REMOVAL of IMPELLER for Replacement of Standard PUMP SEAL (1R303)

DISCONNECT and LOCK-OUT ELECTRIC POWER TO WASHER BEFORE PROCEEDING !!

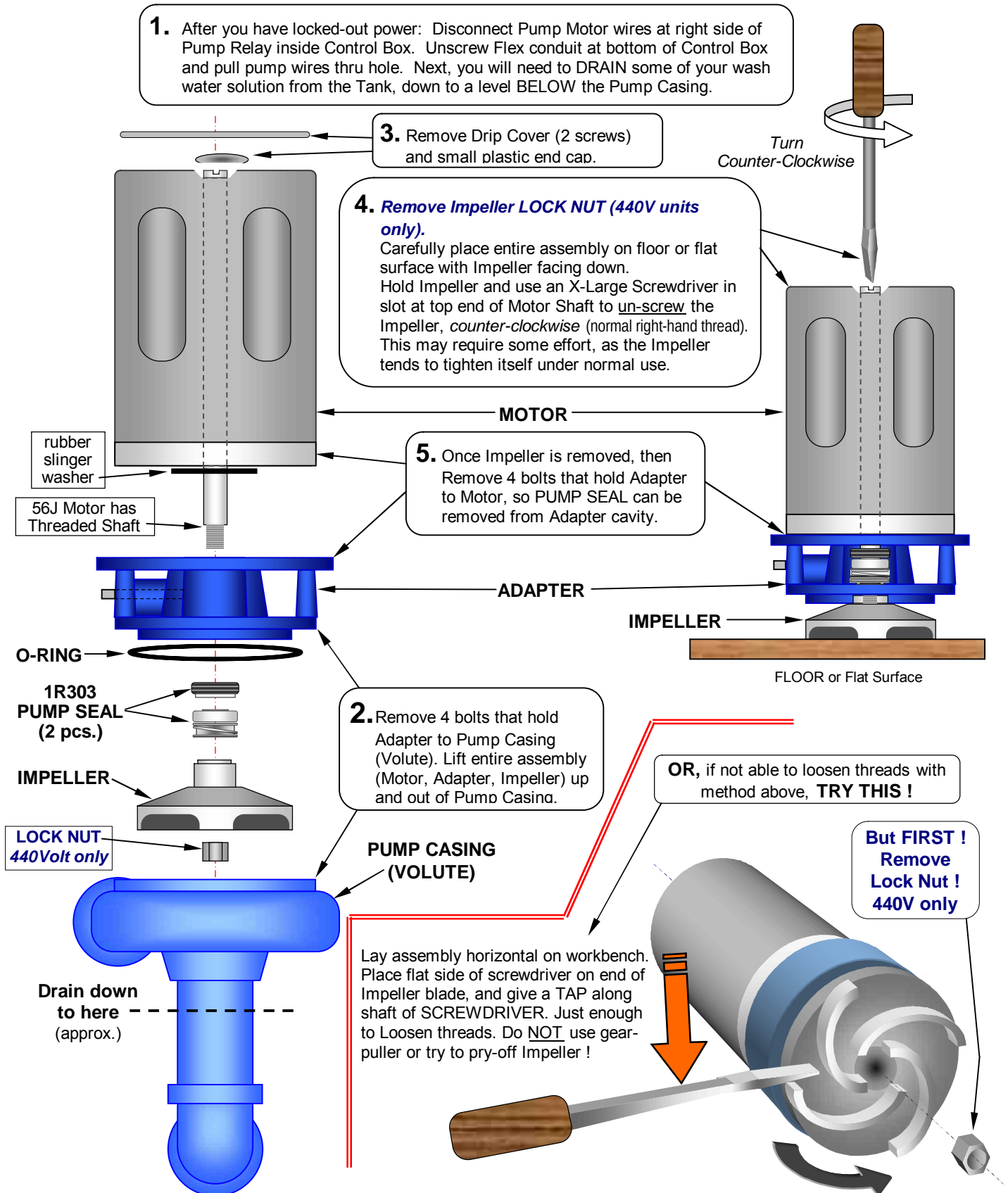

The following info does NOT apply to units equipped with a Heavy Duty SEALLESS Pump & Motor (5HP or 2HP) assembly !

INSTALLATION OF STANDARD MECHANICAL PUMP SEAL (1R303)

One Extra/Spare PUMP SEAL (Grainger part no.1R303) is included and shipped with *POWERJET models 50-80-100* equipped with a standard 120GPM Pump & 1½HP Motor assembly. It is packed (a small box, 1½" x 1½" x 1½") in the plastic bag along with this Manual.

FOR LUBRICATION:

- USE WATER SOLUTION OF SOAP OR DETERGENT.
- DO NOT OVER LUBRICATE.
- NEVER USE PETROLEUM OILS. (e.g. Baby Oil, Mineral Oil, etc.)(Seal manufacturer's recommendation)
- But, any Lubrication is better than none !

CAUTION: *This seal is a precision product and should be handled accordingly.
Be especially careful of the lapped sealing face of the rotary washer and stationary seat.*

LAPPED RUNNING FACES:

The lapped running face of the rotary seal head and stationary seat must be treated with care. KEEP CLEAN, DO NOT SCRATCH. Use a clean, soft cloth during installation. Protect the faces. Install both the seat and rotary square to the shaft.

Check stationary seat installation from behind seat cavity for squareness.

STATIONARY SEAT:

Clean seal cavity in pump adapter. Lubricate rubber "O" –Ring or rubber cup and press seat firmly and squarely into seal cavity with lapped face up. Must be pushed square and all the way into the cavity. Be careful not to scratch lapped face. Use a clean, soft cloth to protect seal face.

ROTARY SEAL HEAD

Clean, Polish and Lubricate shaft or shaft sleeve. Check lapped faces on stationary seat and rotary seal head. Be certain no dirt is on either face. Lubricate rubber bellows. Slide rotary seal head on shaft. Press on metal drive band until the two faces touch. Install impeller. This will compress the spring to proper height. This compression assures the proper pressure on the lapped running faces.

CAUTION

*Never run the lapped faces dry. The liquid being pumped insures proper lubrication.
In some cases a short running period is required to clear up slight leakage.*

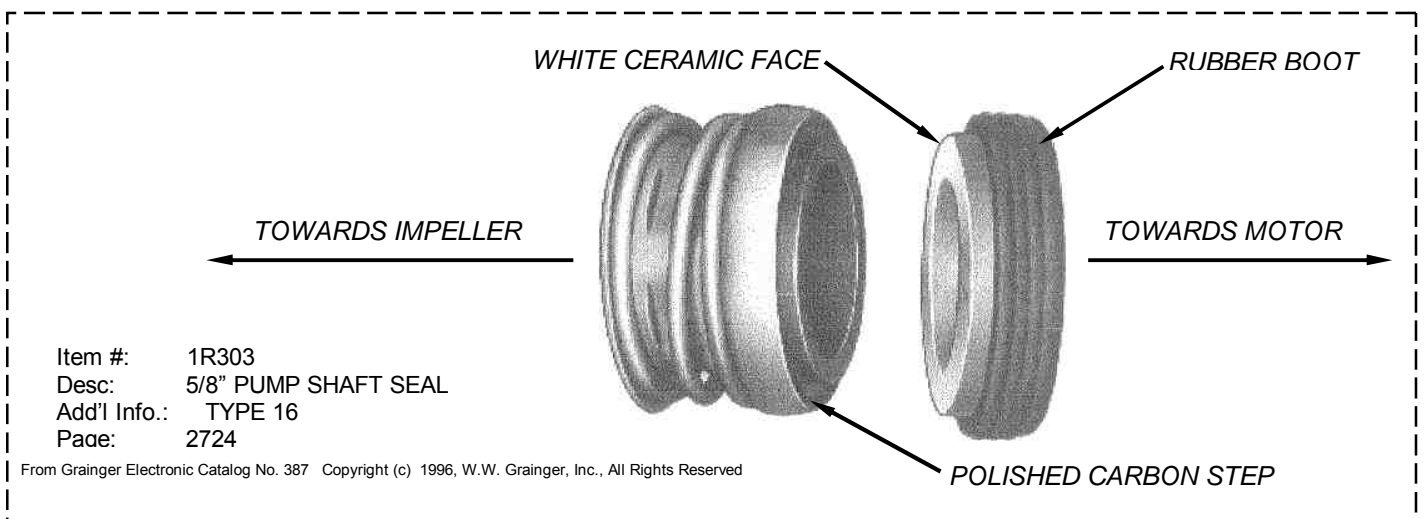
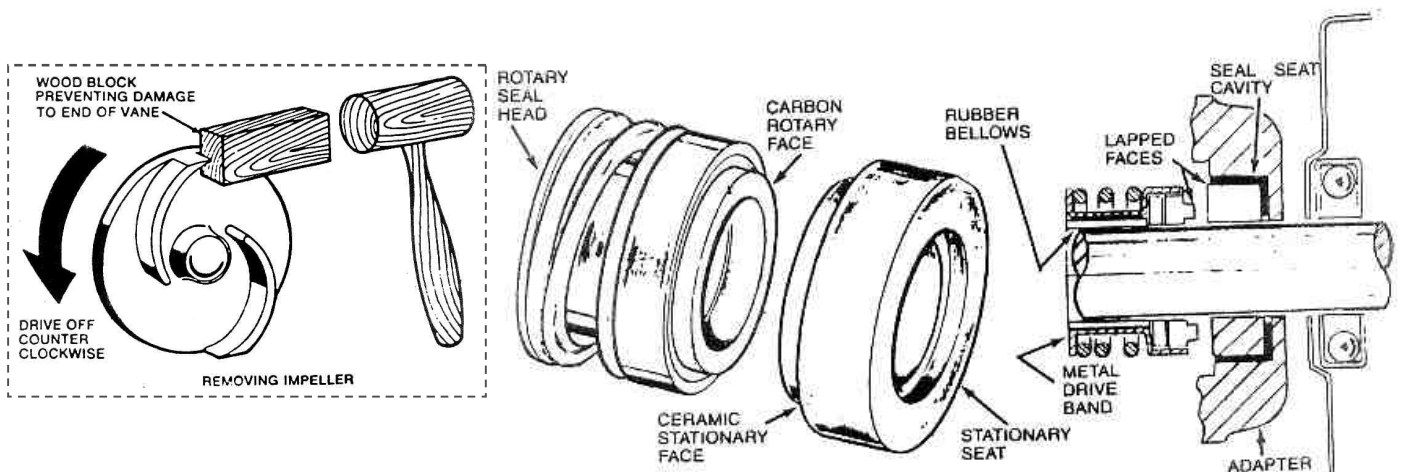

| | | | |
|--|--------------------------------------|--|---------------------------------------|
| Wiring Diagram for : | | EMC® POWERJET® | models: 50E, 80E, 100E, T100E, |
| dwg: PJ-50E80E100E-1.5HP-220V-3PH-40A BC-01-30-2002 | | AUTOMATIC PARTS WASHER | DS80E, DS100E |
| standard Electric Heated | with standard 1½HP pump Motor | 220Volt / 3Ø (three phase) / 40Amps | |

Drawing Not to Scale

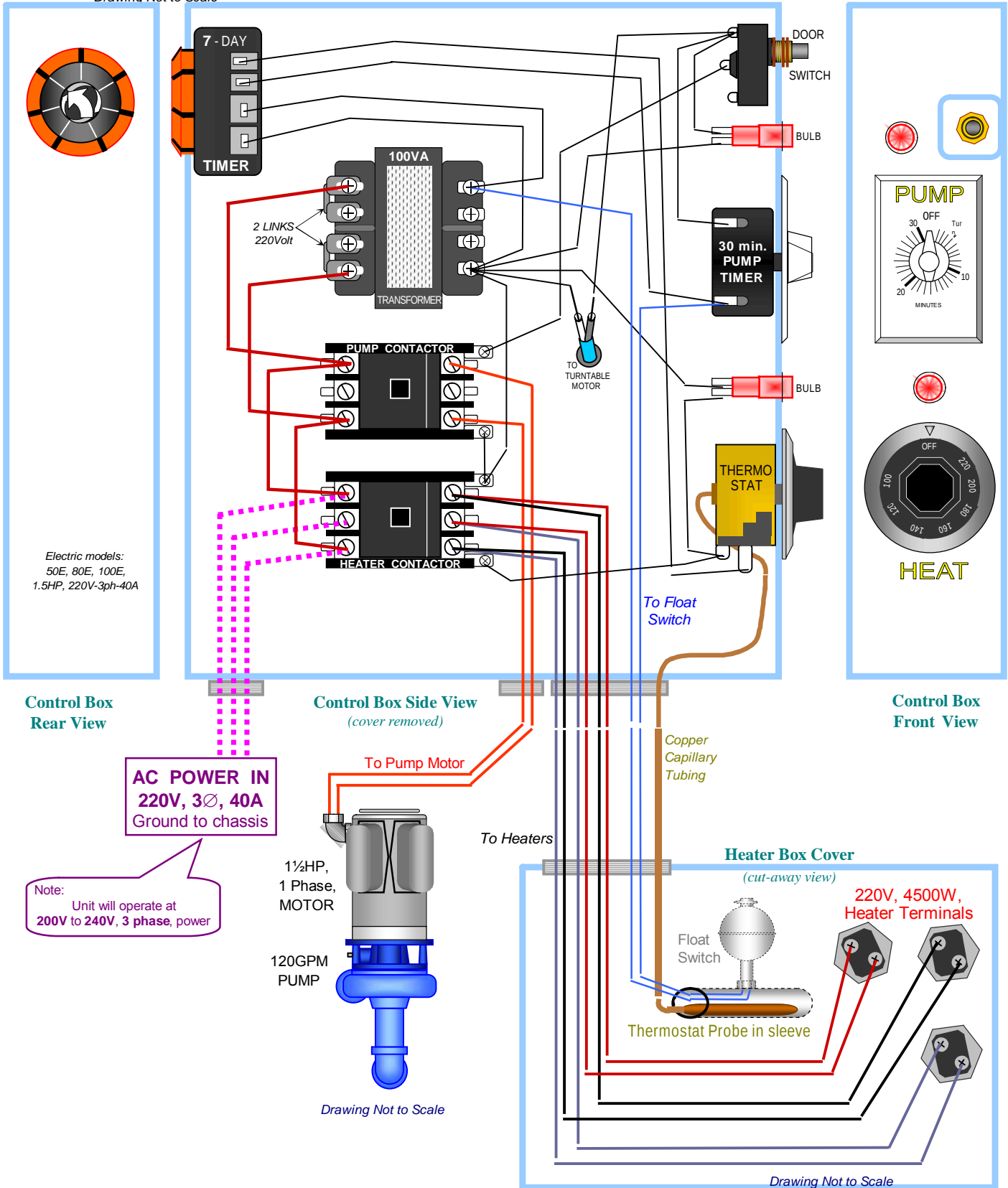

Instructions for POWERJET®, 220Volt - 3phase

CONVERSION to SINGLE PHASE

EMC® POWERJET® models: 50E, 80E, or 100E - 220 VOLT units, are wired at the Factory for 220Volt / 3 PHASE / 60 cycle / 40 Amp – AC Power Hook-up !
These 220 VOLT - 3 PHASE units CAN be Converted to run on SINGLE-PHASE power !

ONLY QUALIFIED PERSONNEL SHOULD PERFORM ELECTRICAL CONNECTIONS !
CAUTION: DIS-CONNECT and LOCK-OUT ALL POWER BEFORE PROCEEDING !

Single Phase HEATER WIRING:

- 1** The center terminals on both the left and the right sides of the HEATER CONTACTOR will NOT be used.
- 2** One Pair of Heater Wires each of the same color (i.e. red & red, OR white & white, OR black & black) are taped off and NOT used.
- 3** Two Heater Wires, each of a different color (i.e. black & red, OR white & red, OR black & white), connect to the top right side main terminal of the Heater Contactor.
- 4** The Two Remaining Heater Wires, (also each of a different color), connect to the bottom right side main terminal of the Heater Contactor.

Single Phase Power LINE IN WIRING:

- 5** GROUND connection is to the chassis (same as the Three-Phase hook-up).
- 6** LINE IN (220V-Single-Phase, AC power) connection is to the upper and lower main terminals on the left-hand side of the Heater Contactor.
- 7** Connect to a Properly Fused (breakered) **50Amp, 220V, 60Hz, Single-Phase**, AC power source.

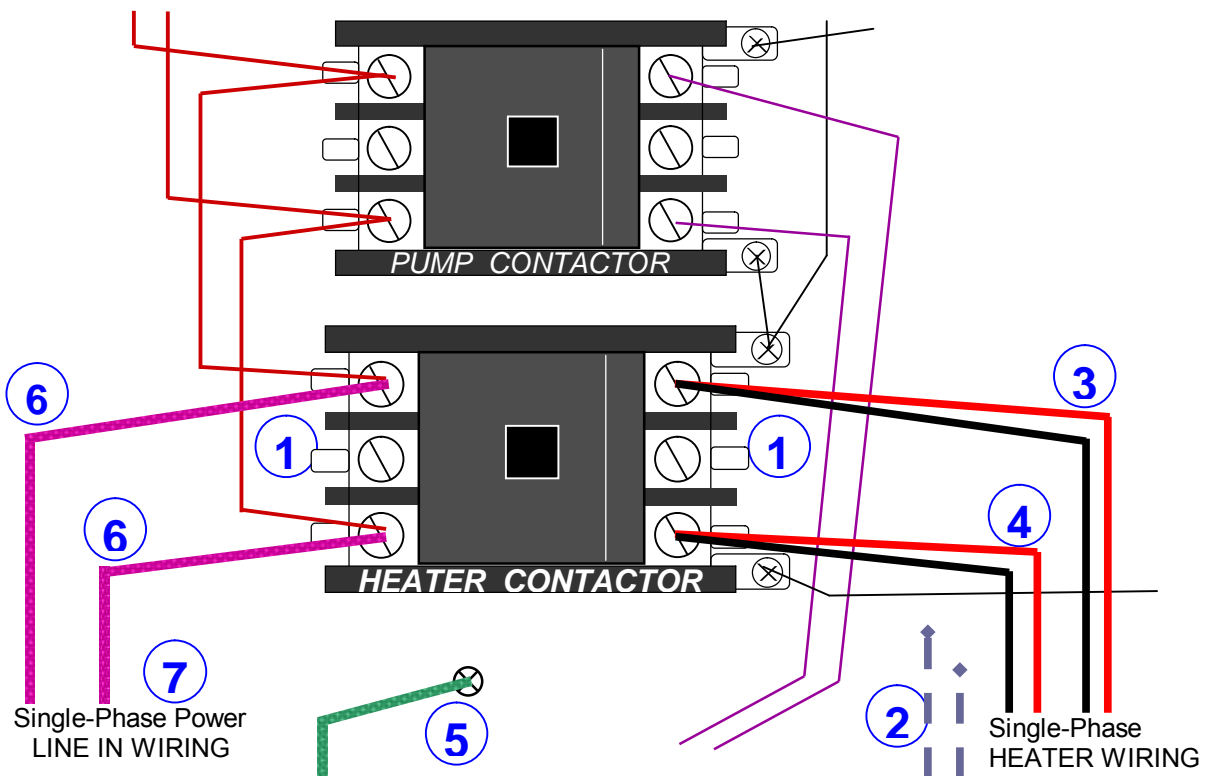

| | | | |
|--|-------------------------------------|--|-------------------------------------|
| Wiring Diagram for : | | EMC® POWERJET® | models: 150E, T150E, DS150E, |
| dwg: PJ-150E200E-5HP-220V-3PH-80A BC-03-07-2002 | | AUTOMATIC PARTS WASHER | 200E, T200E, DS200E |
| standard Electric Heated | with standard 5HP pump Motor | 220Volt / 3Ø (three phase) / 80Amps | |

Drawing Not to Scale

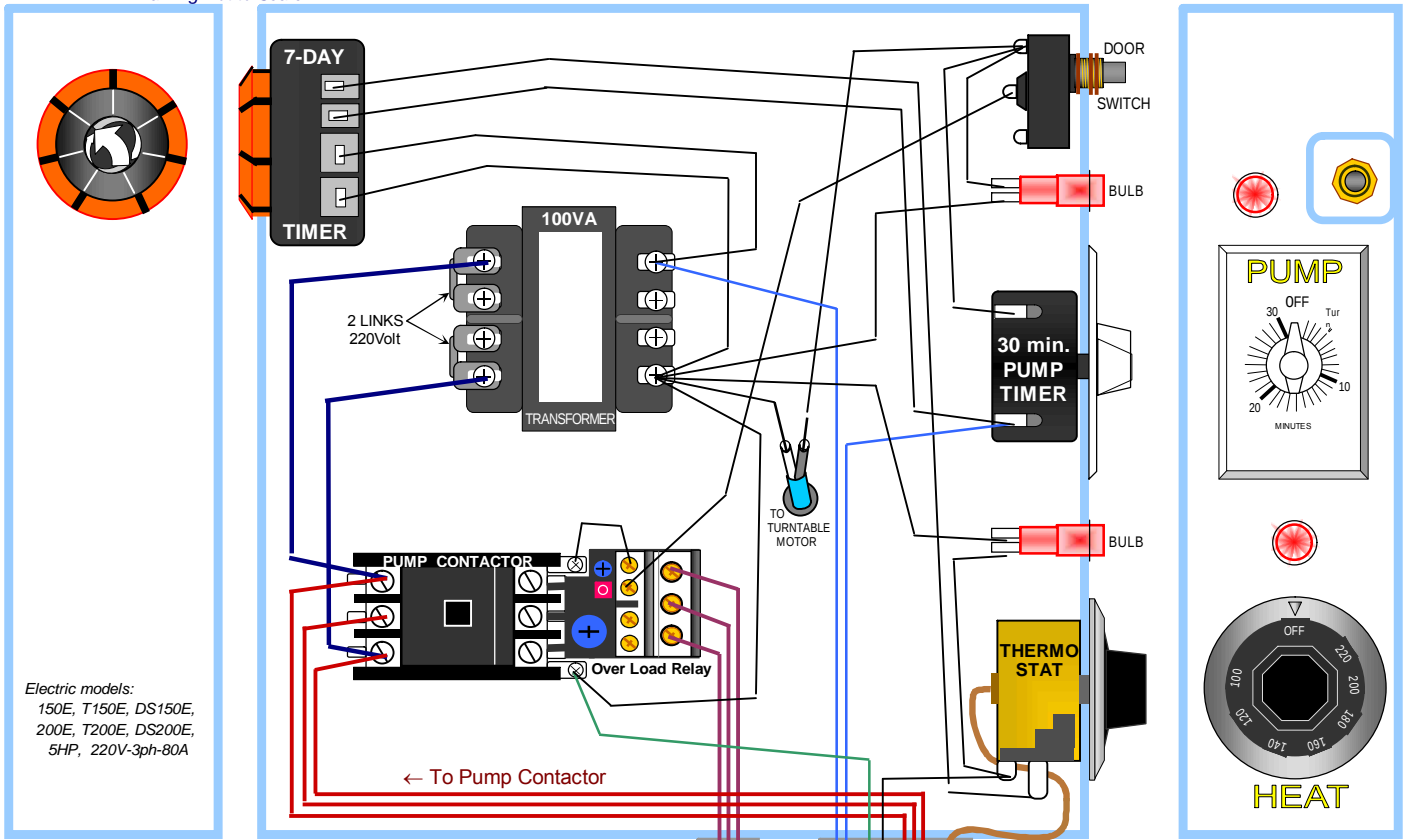

Electric models:
150E, T150E, DS150E,
200E, T200E, DS200E,
5HP, 220V-3ph-80A

Control Box Rear View

Control Box Side View (cover removed)

Control Box Front View

IMPORTANT!
CHECK THAT
PUMP MOTOR
ROTATION IS
CLOCKWISE AS
VIEWED FROM
TOP!

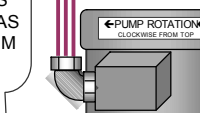

Heavy Duty,
280GPM,
SEALLESS
PUMP

PUMP WELL

Drawing Not to Scale

Note:
Unit will operate at
200V to 240V,
3 phase, power

AC POWER IN
220V, 3Ø, 80A
Ground to chassis

← To Pump Motor

To Float Switch

Copper
Capillary
Tubing

Heater Box Cover (cut-away view)

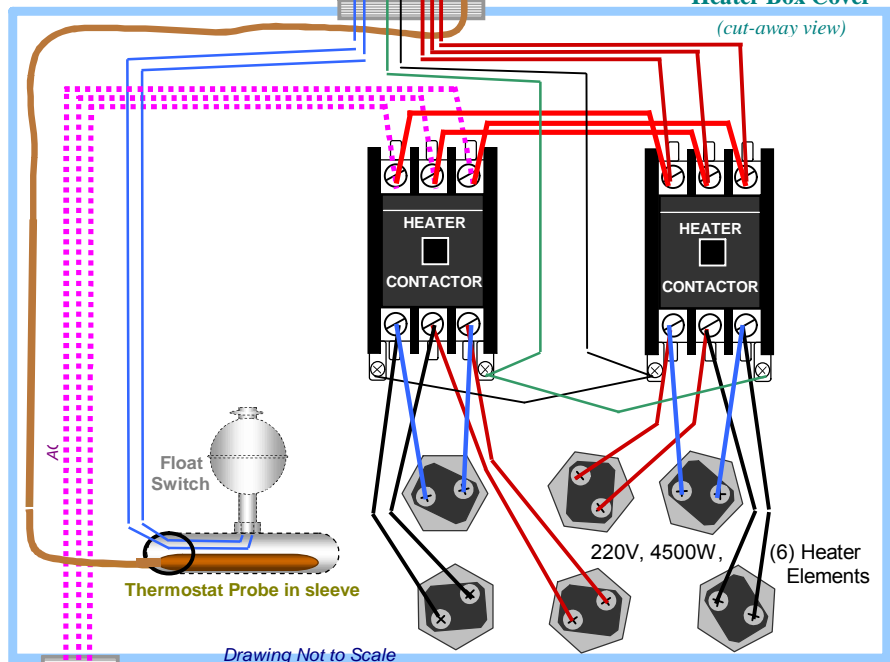

Drawing Not to Scale

| | | | |
|--|-------------------------------------|--|-------------------------------|
| Wiring Diagram for : | | EMC® POWERJET® | models : 150G, T150G, DS150G, |
| dwg: PJ-150G200G-5HP-220V-3PH-20A BC-02-06-2002 | | AUTOMATIC PARTS WASHER | 200G, T200G, DS200G |
| standard GAS Heated | with standard 5HP pump Motor | 220Volt / 3Ø (three phase) / 20Amps | |

Drawing Not to Scale

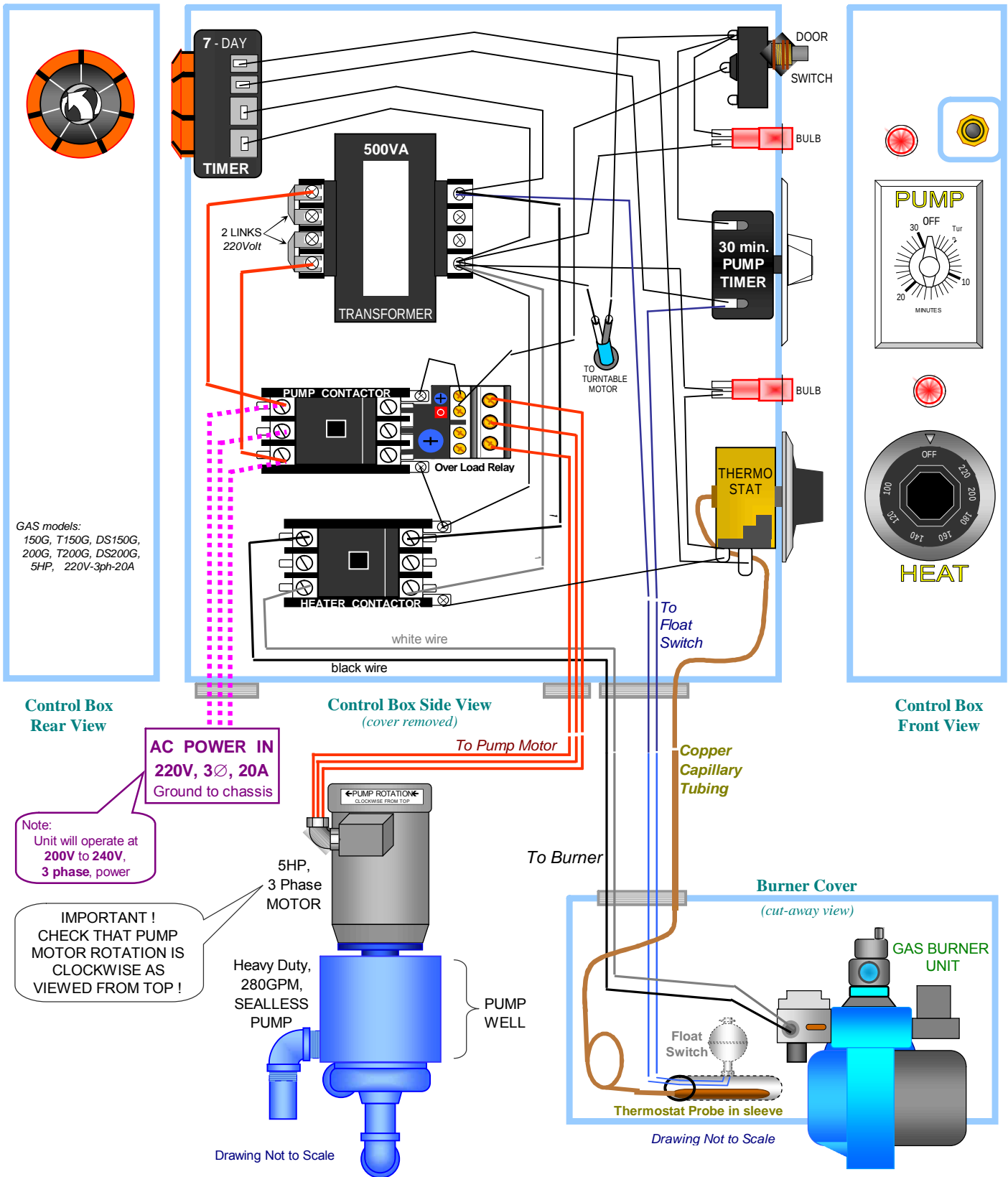

PARTS LIST for:
EMC ® POWERJET® Automatic Parts Washer models: 50, 80, 100, 150, 200 series

| EMC Item No. | Name of Part | Description | Ship Wt. | GRAINGER Part No. | Notes and Application Details |
|--------------------------|-----------------------------------|---------------------------|----------|-------------------|--|
| CABINET ITEMS | | | | | |
| PJ101 | TurnTable BEARING | 50,80,100, series | 3 | | with Pulley attached, available only atEMC |
| PJ102 | TurnTable BEARING | 150,200, series | 4 | | with Pulley attached, available only atEMC |
| PJ103 | TurnTable MOTOR with Pulley | w/o mounting bracket | 3 | 2Z805 | Pulley Not available at Grainger, only at EMC |
| PJ104 | TurnTable DRIVE BELT | 50,80,100, series | 1 | 4L170 | 17 inch |
| PJ105 | TurnTable DRIVE BELT | 150,200, series | 1 | 4L190 | 19 inch |
| PJ106 | Wash AREA Filter SCREEN | 50, 80, series | 6 | | \$\$ Stainless Steel is 1.50 x (1½ times) carbon steel price |
| PJ107 | Wash AREA Filter SCREEN | 100 series | 8 | | Rare model 150 Area Screen is \$ 70.00, 15 lbs. |
| PJ108 | FLOAT SWITCH | "Liquid Level Control " | 1 | 2A551 | |
| PJ109 | Pump Intake STRAINER | | 3 | 1P690 | |
| PJ112 | 2" BALL VALVE for Drain or | Variable Weir Skimmer | 6 | | 2 valves per unit |
| PTPJ113 | Pass-Thru DOOR CABLE | PT100, PT150, PT200series | 2 | | PASS-THRU models ONLY, 2 cables per unit(4 lbs) |
| PTPJ114 | Pass-Thru DOOR SWITCH | PT100, PT150, PT200series | 1 | 3A095 | PASS-THRU models ONLY, 2 switches per unit |
| PTPJ115 | Pass-Thru ROLLER BEARING | PT100, PT150, PT200series | | | Shatz #AF3252 |
| HEATER ELEMENTS | | | | | |
| 220LWD4500 | Low Watt Density Heater Element | 220V, 4500W | | | EMC standard Heater Elements since 2002 |
| 440LWD4500 | Low Watt Density Heater Element | 440V, 4500W | | | 3 Heaters on 50-80-100 series, 6 Hrs on 150-200 series |
| 220PJ4500 | Old style Electric Heater Element | 220V, 4500W | 3 | 2E673 | 220Volt only, . . Not available at EMC |
| CONTROL BOX ITEMS | | | | | |
| PJ201 | 7 Day TIMER | | 1 | | |
| PJ202 | TRANSFORMER 100 VA | for ELECTRIC ONLY | 5 | 4R822 | ELECTRIC Heated models ONLY |
| GPJ203 | TRANSFORMER 500 VA | for GAS ONLY | 12 | | GAS Heated models ONLY |
| PJ204 | CONTACTOR 2 per unit | For Heater & Pump Motor | 3 | 5B109 | 150E and 200E series - 3 per unit(2 for heaters) |
| PJ204-OLR | OVER LOAD RELAY 440Volt | or 3-Phase pump Motor | | | |
| PJ205 | DOOR Micro-SWITCH | "Door Safety Switch" | 1 | 6X288 | |
| PJ206 | Indicator BULB | | 1 | | 2 bulbs per unit |
| PJ207 | 30 minute TIMER | | 1 | 2E175 | |
| PJ208 | THERMOSTAT with probe, | sensor and tubing coil | 1 | | Knob Only - \$5.00 |

Continued:

PARTS LIST for EMC ® **POWERJET®** Automatic Parts Washer models: 50, 80, 100, 150, 200 series,

| EMC item no. | | | Ship Wt | GRAINGER Part No. |
|--|---|---|------------|--|
| Standard Sealed PUMP & MOTOR ITEMS | | | | |
| PSK300 | PUMP SEAL KIT - includes 2 Seals with 2 Lube Packets , and 1 O-Ring | | 1 | |
| PJ301-1ph | Std. Pump MOTOR, 220V, 1-phase | 1½HP , 56J-ODP | 25 | 2K370 (Marathon) 5K475 (Dayton) |
| PJ301-3ph | Std. Pump MOTOR, 440V, 3-phase | 1½ HP , 56J-ODP | 25 | 4N065 (Marathon) |
| PJ302 | Standard PUMP ASSEMBLY (No motor) | Includes: cast-iron Volute & Adapter, Impeller, Seal, and O-ring | 23 | |
| PJ302-C | Custom Pump & Motor Pre-Assembled, Ready to Install on your Existing volute | Includes: 1½HP Motor, Adapter, Impeller, Seal, and O-ring | 37 | |
| PJ303 | Std. Pump SEAL | 2 pieces = 1 Seal | 1 | 1R303 |
| PJ304 | Std. Pump O-RING | 4½" diam. rubber O-ring, Dash#246 | 1 | |
| PJ305-4.38 | Std. Pump IMPELLER , for std 1½HP motor | 4¾" diameter, cast iron | 3 | |
| PJ305-3.88 | Other Impeller Diameter . . . for 1HP motor, on old-style washers, Not in current production | must trim to 3¾" diameter | 3 | |
| PJ306 | Std. Pump ADAPTER (top of casing) | "adapts" motor to pump - cast iron | 8 | |
| PJ307 | Std. Pump VOLUTE (bottom of casing) | pump inlet & outlet - cast iron | 12 | |
| | | | | |
| EMC item no. | | | Ship Wt | Available at: |
| SEALLESS PUMP & MOTOR ITEMS | | | | |
| SLP321-3ph | SealLess Pump MOTOR, 5HP, 3-phase , | 220V or 440V, 3-phase , | 65 | EMC or SCOT Pump |
| SLP321-1ph | SealLess Pump MOTOR, 5HP, 1-phase , | 220V, 1-phase, for 220V only ! | 65 | EMC or SCOT Pump |
| SLP322 | SealLess Pump <i>Column VAPOR SEAL</i> | <i>Nat'l Seal No. 471192, at Auto Parts or Bearing & Seal stores,</i> | | n/a |
| SLP323 | SealLess Pump Motor ADAPTER | 12" cast iron column, top of case, includes Vapor Seal | 21 | EMC or SCOT Pump |
| SLP324 | SealLess Pump WELL | 10" diam. x 10" deep, fittings custom fit & welded at EMC | 16 | EMC |
| SLP325 | SealLess Pump <i>Well GASKET - Not Available</i> | Use 3M 5200 Poly-Urethane Sealer | | n/a |
| SLP326 | SealLessPump THROTTLE SLEEVE | (motor shaft bushing) | 1 | EMC or SCOT Pump |
| SLP327 | SealLess Pump IMPELLER | 5½" diameter | 3 | EMC |
| SLP328 | SealLess PUMP CASE (VOLUTE) | bottom of casing - cast iron | 18 | EMC or SCOT Pump |
| SLP329 | SealLessPump PLUMBING HOSE | 1½" to 1½", with clamps | 1 | EMC |
| SCOT PUMP Co. . . . 262-377-7000 <i>Cedarburg, Wisconsin 53012</i> | | | | |
| OPTIONAL 2HP MOTOR, for Sealless Pump | | | | |
| SLP381-3ph | SealLess Pump MOTOR, 2HP, 3-phase , | 220V or 440V, 3-phase , | 65 | EMC or SCOT Pump |
| SLP381-1ph | SealLess Pump MOTOR, 2HP, 1-phase , | 220V, 1-phase, for 220V only ! | 65 | EMC or SCOT Pump |
| SLP387 | Sealless Pump IMPELLER for 2HP motor | 4¾" diameter | 3 | EMC |

ALL Prices are subject to change without notice. Shipping charges and taxes, where applicable, are extra.

Continued:

PARTS LIST for EMC ® POWERJET® Automatic Parts Washer models: 50, 80, 100, 150, 200 series,

| WAYNE Part No. | NAME of PART | Description | Approx Ship Wt | Notes |
|-----------------|--------------------------------------|-----------------------|----------------|--|
| 62377C | GAS BURNER ASSEMBLY | EMC no. HSG400 | 30 | WAYNE MODEL HSG400 BURNER |
| 62374-004 | GAS VALVE | | 3 | JET size : # 281 Natural Gas |
| 62402 | ORIFICE HOUSING | | | |
| 62401-001 | ORIFICE GASKET | | | |
| 62759-002 | PRIMARY CONTROL | " BRAIN " | 1 | |
| 62390-002 | FLAME SENSOR PROBE | | 1 | |
| 62411-028 | Flame Sensor to Brain WIRE | | | |
| 61951-001 | ELECTRODE BRACKET | | | WAYNE COMBUSTION 219-425-9200 <i>Fort Wayne, Indiana</i> |
| 62391-002 | ELECTRODE | " Spark Plug " | 1 | |
| 62909-001 | IGNITION WIRE | | | |
| 62407-001 | IGNITION TRANSFORMER | 7300V | 5 | |
| 60186-004 | 24 Volt TRANSFORMER | | 2 | |
| 63263-001 | Old Pressure / Vacuum SWITCH | 2 ¼" diam. "disk" | 1 | Black & Blue plastic "disk" - "hockey puck" |
| | Clear Hose - for above switch | ½" x 12" Length | | " |
| 63263-005 | NEW Pressure / Vacuum SWITCH | 2 ¼" diam. "disk" | | Black & White plastic "disk" - "hockey puck" |
| | Clear Hose - for above switch | ¼" x 9½" Length | | |
| 100968-002 | Hose Barbed Fitting - for above | ¼" hose x ¼"-20thread | | |
| 20627 | BLOWER MOTOR | | | 1/7 HP, Frame 48M |
| 62406-002 | Blower Motor RELAY SWITCH | | | |
| 100371 | OFF CYCLE DAMPER PLATE & BRACKET KIT | | | |
| 62624-005 | Nameplate Decal | <i>At EMC</i> | | |
| 62484-001 | Burner Instruction Manual | <i>At EMC</i> | 1 | |
| 62376C | Early GAS BURNER Assembly | HSG200 | 30 | For GAS units built Nov1995 thru Feb1998, with 4½" FireTube, approx s/n3312895 3347995, 33671095, 34041195 thru xxxx0298 |
| EMC part | Burner COVER | EMC no. HSG-BC | | Factory made at EMC |

ALL Prices are subject to change without notice. Shipping charges and taxes, where applicable, are extra

| POWERJET® ACCESSORIES: | | | Approx.Weight |
|-------------------------------|--------------------------------------|---------------------------------------|----------------------|
| EMC Item No. | Name of Part | Description & Dimensions | Boxed, Ready to Ship |
| 1010SPB | Small Parts BASKET . . . small size | 10" x 10", Perforated Metal | 8 |
| 1216SPB | Small Parts BASKET . . . medium size | 12" x 16", Perforated Metal | 13 |
| 1721SPB | Small Parts BASKET . . . Large size | 17" x 21", Heavy Expanded Metal | 20 |
| 524PB | std. 50 & 80 TurnTable BASKET | 5½" x 24½", Heavy Expanded Metal | 17 |
| 531PB | std. 100 TurnTable BASKET | 5½" x 31", Heavy Expanded Metal | 22 |
| 542PB | std. 150 TurnTable BASKET | 5½" x 42", Heavy Expanded Metal | 30 |
| 554PB | std. 200 TurnTable BASKET | 5½" x 54", Heavy Expanded Metal | 45 |
| 2429HR | HEAD RACK or "PARTS TREE" | 24" diam. x 29" center Ht. | 25 |
| 1624HB | HOISTING BAR . . . for 100 size | 16" deep x 24" high, . . inside reach | 15 |
| 2224HB | HOISTING BAR . . . for 150 size | 22" deep x 24" high, . . inside reach | 25 |
| 2624HB | HOISTING BAR . . . for 200 size | 26" deep x 24" high, . . inside reach | 28 |
| 3624RTC | ROLLER-TOP CART . . for Pass-Thru | 36" Length x 24" wide | 165+ |
| 1212DCP | DOUBLE CONTAINMENT PAN | 12GA. steel, 12" deep | 200+ |

* ALL Prices are subject to change without notice. Shipping charges and taxes, where applicable, are extra.

Remember ! : You can order parts thru Distributor that originally sold the POWERJET unit,

OR,

You can order parts from **EMC** factory, phone 888-833-9000 FAX: 562-623-9342

Email: sales@equipmentmanufacturing.com or: emcdirect@earthlink.net

- Parts ordered from **EMC** factory will be shipped via UPS.

PARTS FOR MUCH-OLDER (early 1980's & 90's) EMC ® Auto. Parts Washer models: 50, 80, 100, 150, 200 series.

These Components are NOT used on current production POWERJETS !

| EMC Item No. | NAME of PART | Description | Ship Weight | GRAINGER Part No. | OTHER NOTES and DETAILS |
|---|--------------------------------|-----------------------------|-------------|-------------------|---|
| OLDER CONTROL BOX COMPONENTS | | | | | |
| 7DT-2E214 | 7-Day Timer, | 12x12 gray box | | 2E214 | First type of Timer, 12" x 12" gray box |
| 7DT-2A518 | 7-Day TIMER all Black set-pins | in Orange Ring | | 2A518 | Looks similar to 7-day Timer with RED & Black set-pins |
| GPJ24VT | 24 Volt TRANSFORMER | | 2 | 4X746 | Older Style GAS Units ONLY ! (see below) |
| GPJ483 | Ignition Control – "BRAIN" | | 1 | | Older Style GAS Units ONLY ! (see below) |
| OPJ159 | FUSE, 1Amp, Gen'l Purpose | BAF, 250VAC | 1 | 6F159 | Also on Transformers starting Nov7-02, s/n60751002 |
| OPJ160 | FUSE, 2Amp, Gen'l Purpose | BAF, 250VAC | 1 | 6F160 | A Few Older Style Units ONLY ! |
| OPJ840 | TRANSFORMER | 150 VA | 7 | 4R840 | A Few Older Style Units ONLY ! |
| OPJ847 | PUMP CONTACTOR | 2 Pole, DoubleThrow | 2 | 5X847 | Older Style Units ONLY ! 1995? And earlier. (same as on current AUTO-FILL and JETSINK-110V) |
| OLDER 2HP MOTOR, for Sealless Pump | | | | | |
| SLP381 | Sealless Pump MOTOR 2HP | 3-phase, 220V or 440V, | 60 | at EMC | OR at SCOT PUMP, VFE-17 |
| SLP381 | Sealless Pump MOTOR 2HP | 1-phase, for 220V only ! | 60 | at EMC | OR at SCOT PUMP, VFE-17 |
| SLP387 | Sealless Pump IMPELLER | 4¾" diameter, for 2HP motor | 3 | at EMC | SCOT PUMP Co. . . . 262-377-7000 Cedarburg, Wisconsin 53012 |

Automatic Parts Washer, Parts for OLD PREVIOUS STYLE - models: 50, 80, 100, 150, 200 series, continued:

OLDER STYLE ATMOSPHERIC BURNER - PARTS

| EMC Item No. | NAME of PART | Description | Ship Weight | GRAINGER Part No. | OTHER NOTES and DETAILS |
|---------------------------------|----------------------------|------------------|-------------|-------------------|---|
| OLDER GAS UNITS | | | | | |
| GPJ-DJ3 | DRAFT INDUCER (BLOWER) | model DJ-3 | 8 | 4C730 | (same Blower as currently used on 85E) |
| GPJ24VT | 24 Volt TRANSFORMER | Control Box Item | 2 | 4X746 | Older Style GAS Units ONLY ! |
| ATMOSPHERIC BURNER PARTS | | | | | |
| GPJ482A | Brass ADAPTER & JET | Threaded | | n/a | JET SIZES: model 50 & 80 = #32 Nat.Gas Model 100 = #28 Nat.Gas, #38 Propane Model 150 & 200 = #22 Nat.Gas |
| GPJ482B | Cast Iron BURNER | | 3 | n/a | |
| GPJ482D | Air Adjustment Disk | | | n/a | |
| GPJ483 | Ignition Control - "BRAIN" | Control Box Item | 1 | 6KXC6 | ♣ Robertshaw part no. 780-715 |
| GPJ484 | GAS VALVE | | 3 | 6KXC8 | ♣ Robertshaw part no. 720-079 |
| GPJ485 | SENSOR (Heat Probe) | | 1 | | ♣ Robertshaw part no. 10-227 |
| GPJ486 | PILOT Assembly | | | n/a | Available at EMC |

♣ **BURKE ENGINEERING has Closed-Up, Gone Out-of Business ! . . . parts Not available there any longer.**

Robertshaw Parts once were available at BURKE, but, Not anymore !

TRY GOOGLE, on the Internet !!

Enter it in the Search Bar like this: Robertshaw 720-079

EMC® POWERJET® AUTOMATIC PARTS WASHERS

STANDARD FEATURES:

- FULLY INSULATED CABINET
- PARTS BASKET
- VARIABLE WEIR OIL SKIMMER
- FRONT DOOR LOADING
- 7-DAY HEAT TIMER
- LOW WATER SHUTOFF

SPECIFICATIONS

| UTILITIES | MODEL No. | MAXIMUM LOAD SIZE | LOAD CAPACITY (lbs.) | TANK SIZE (gallons) | PUMP GPM | PUMP MOTOR HP | VENT PIPE I.D. | Approx. Ship Weight |
|--|-----------------|-------------------|----------------------|---------------------|----------|---------------|----------------|---------------------|
| ELECTRIC HEATED UNITS 13,500 Watts 220V - 3ph - 40A OR 9,000 Watts 220V - 1ph - 50A OR Optional 440V-3ph-20A | 50 E | 28" x 30"T | 750 | 50 | 120 | 1½ | 4" | 700 lbs |
| | 80 E | 28" x 38"T | 750 | 80 | 120 | 1½ | 4" | 770 lbs |
| | DS 80 E | 28" x 74"T | 750 | 80 | 120 | 1½ | 6" | 1100 |
| | 100 E | 34" x 38"T | 750 | 100 | 120 | 1½ | 6" | 950 lbs |
| | T 100 E | 34" x 50"T | 750 | 100 | 120 | 1½ | 6" | 1100 |
| | DS 100 E | 34" x 74"T | 750 | 100 | 120 | 1½ | 6" | 1300 |
| | PT 100 E | 34" x 36"T | 750 | 100 | 120 | 1½ | 6" | 1200 |
| | 100 G | 34" x 38"T | 750 | 100 | 120 | 1½ | 6" | 1100 |
| | T 100 G | 34" x 50"T | 750 | 100 | 120 | 1½ | 6" | 1200 |
| GAS HEATED UNITS 220V - 3ph - 20A | 150 G | 46" x 37"T | 1200 | 150 | 280 | 5 | 10" | 1600 |
| | T 150 G | 46" x 50"T | 1200 | 150 | 280 | 5 | 10" | 1750 |
| | DS 150 G | 46" x 74"T | 1200 | 150 | 280 | 5 | 12" | 1900 |
| | PT 150 G | 46" x 35"T | 1200 | 150 | 280 | 5 | 10" | 1800 |
| ADJUSTABLE 140,000 to 250,000BTU Std. ¾" NPT Gas Line | 200 G | 58" x 36"T | 1200 | 200 | 280 | 5 | 12" | 1800 |
| | T 200 G | 58" x 50"T | 1200 | 200 | 280 | 5 | 12" | 2000 |
| | DS 200 G | 58" x 74"T | 1200 | 200 | 280 | 5 | 12" | 2350 |
| | PT 200 G | 58" x 35"T | 1200 | 200 | 280 | 5 | 12" | 2000 |
| ELECTRIC HEATED 27,000 Watts 220V - 3ph - 80A OR 440V - 3ph - 40A | 150 E | 46" x 37"T | 1200 | 150 | 280 | 5 | 10" | 1450 |
| | T 150 E | 46" x 50"T | 1200 | 150 | 280 | 5 | 10" | 1600 |
| | DS 150 E | 46" x 74"T | 1200 | 150 | 280 | 5 | 12" | 1750 |
| | PT 150 E | 46" x 35"T | 1200 | 150 | 280 | 5 | 10" | 1600 |
| | 200 E | 58" x 36"T | 1200 | 200 | 280 | 5 | 12" | 1600 |
| | T 200 E | 58" x 50"T | 1200 | 200 | 280 | 5 | 12" | 1800 |
| | DS 200 E | 58" x 74"T | 1200 | 200 | 280 | 5 | 12" | 2150 |
| | PT 200 E | 58" x 35"T | 1200 | 200 | 280 | 5 | 12" | 1800 |

WARRANTY & LIMITATION OF LIABILITY

NOTE: EQUIPMENT MANUFACTURING CORPORATION (EMC) MAKES NO WARRANTY CONCERNING APPLICABILITY OF THE EQUIPMENT TO ANY PARTICULAR FLUID. FINAL DETERMINATION OF APPROPRIATENESS OF THIS EQUIPMENT FOR ANY USAGE IS THAT OF THE CUSTOMER.

EMC through its Distributor warrants each new product sold by it to the initial user to be free of defects in material and workmanship for a period of One Year from the date of sale of the equipment. F.O.B. Santa Fe Springs, CA.

EMC will provide a new part or repaired part, at its election, in place of any part which is found, upon inspection, to be defective in material and workmanship during the period described above. Purchaser must present proof of purchase (and purchase date) at the time of exercising this warranty.

This warranty does not apply to failures occurring as a result of incompatibility of fluid type to material of construction, abuse, misuse, negligent repairs, corrosion, and normal wear and tear, alteration or modifications made to the product without express written consent of **EMC** or failure to follow the recommended operating practices and maintenance procedures as provided in the product's operating and maintenance publications.

The warranty provided herein does not apply to equipment sold hereunder but manufactured by others as they are warranted by their respective manufacturers directly to the user, as electric motors, engines and magnetic starters.

THIS WARRANTY IS IN LIEU OF ALL OTHER WARRANTIES, EXPRESSED OR IMPLIED, AND THERE ARE NO WARRANTIES, OF MERCHANTABILITY OR OF FITNESS FOR A PARTICULAR PURPOSE.

LIMITATION OF LIABILITY

The remedies of the user set forth under the provisions of warranty outlined above are exclusive and total liability of **EMC** or its Distributor with respect to this sale or the equipment and service furnished hereunder, in connection with the performance or breach thereof, or from the sale, delivery installation, or repair or technical direction covered by or furnished under this sale, whether based on contract, warranty, negligence, indemnity, strict liability or otherwise shall not exceed the purchase price of the unit of equipment upon which such liability is based.

EMC shall in no event be liable to the user, any successor in interest or any beneficiary or assignee relating to this sale for any consequential, incidental, indirect, special or punitive damages arising out of this sale or any breach thereof, or any defects in, or failure of, or malfunction of the equipment under this date whether based upon loss of use, lost profits or revenue, interest, lost goodwill, work stoppage, impairment of other goods, loss by reason of shutdown or non-operation, increased expenses of operation, cost of purchase of replacement power or claims of user or customers of the user for service interruption whether or not such loss or damage is based on contract, warranty, negligence, indemnity, strict liability or otherwise.

I have read the **EMC** instructions and agree that they will be followed carefully. I also agree that the equipment will be used at my own risk and agree to hold harmless and indemnity from all claims for damages and liabilities resulting from its improper use.

SIGNED AND DATED FORM MUST BE RETURNED FOR WARRANTY TO BE INSTATED.

Purchase Date _____ Serial No. _____ Model No. _____

DISTRIBUTOR that unit was purchased from: _____

CUSTOMER Signature : _____ COMPANY Name : _____

Print Name : _____ Address : _____

Phone : _____ FAX : _____

Please make a copy of this page for your file and send signed copy to **EMC**.

Send via Mail or FAX to: **Equipment Manufacturing Corporation**
14930 Marquardt Avenue
Santa Fe Springs, CA. 90670
FAX: 562 – 623 – 9342
Email: emcdirect@earthlink.net